

PRODUCT SPECIFICATIONS

Elkay ezH2O® Floor Standing Bottle Filling Station Filtered Refrigerated Stainless Steel. Chilling Capacity of 8.0 GPH (gallons per hour) of 50° F drinking water, based on 80° F inlet water and 90° F ambient, per ASHRAE 18 testing. Features shall include Hands Free, Antimicrobial*, Chilled Water, Filtered, Laminar Flow, Visual Filter Monitor, Green Ticker™. Electronic Bottle Filler Sensor activation. Product shall be Floor Mount/Freestanding, for Indoor applications, serving 1 station(s). Unit shall be certified to UL 399 and CAN/CSA C22.2 No. 120.



| | |
|--|--|
| Special Features: | Hands Free, Antimicrobial, Chilled Water, Filtered, Laminar Flow, Visual Filter Monitor, Green Ticker™ |
| Finish: | Stainless Steel |
| Power: | 115V/60Hz |
| Bubbler Style: | No Bubbler |
| Activation by: | Electronic Bottle Filler Sensor |
| Mounting Type: | Floor Mount/Freestanding |
| Chilling Capacity*: | 8.0 GPH |
| Full Load Amps | 5 |
| Dimensions (L x W x H): | 21-1/2" x 15" x 48" |
| Approx. Shipping Weight: | 94 lbs. |
| Installation Location: | Indoor |
| No. of Stations Served: | 1 |
| *Based on 80° F inlet water & 90° F ambient air temp for 50° F chilled drinking water. | |

- Visual Filter Monitor: LED Filter Status Indicator for when filter change is necessary.
- Filter is certified to NSF 42 and 53 for lead, cyst, particulate, chlorine, taste and odor reduction. 3,000 gal. capacity.
- Green Ticker: Informs user of number of 20 oz. plastic water bottles saved from waste.
- Laminar flow provides clean fill with minimal splash.
- Key plastic components are manufactured with silver ion antimicrobial agent helping to provide clean, stain- and odor-free surfaces.

*Antimicrobial claims are in refence to components manufactured antimicrobial agents, helping to provide clean, stain- and odor-free surfaces.

COOLING SYSTEM

- Compressor: Hermetically-sealed, reciprocating type, single phase. Sealed-in lifetime lubrication.
- Condenser: Fan cooled, copper tube with aluminum fins. Fan motor is permanently lubricated.
- Cooling Unit: Combination tube-tank type. Continuous copper tubing with is fully insulated with EPS foam that

PART: _____ QTY: _____

PROJECT: _____

CONTACT: _____

DATE: _____

NOTES: _____

APPROVAL: _____

Included with Product: Bottle filler, 51300C

Ships in one box.

A Century of Tradition and Quality. For more than 100 years, Elkay has been making innovative products and providing exceptional customer care. We take pride in offering plumbing products that make life easier, inspire change and leave the world a better place.



PRODUCT COMPLIANCE

CAN/CSA C22.2 No. 120
NSF/ANSI 42, 53, 61 (Q≤1), & 372 (lead free)
UL 399



Complies with ADA & ICC A117.1 accessibility requirements when installed according to the requirements outlined in these standards. Installation may require additional components and/or construction features to be fully compliant. Consult the local Authority Having Jurisdiction if necessary.

[Clean and Care Manual \(PDF\)](#)

[Installation Instructions \(PDF\) - 2000000216](#)

5 Year Limited Warranty on the refrigeration system of the unit. Electrical components and water system are warranted for 12 months from date of installation. **Warranty pertains to drinking water applications only. Non-drinking water applications are not covered under warranty.**

[Warranty \(PDF\)](#)

In keeping with our policy of continuing product improvement, Elkay reserves the right to change product specifications without notice. Please visit elkay.com for the most current version of Elkay product specification sheets. This specification describes an Elkay product with design, quality, and functional benefits to the user. When making a comparison of other producers' offerings, be certain these features are not overlooked.

meets UL requirements for self-extinguishing material.

- Refrigerant Control: Refrigerant R-134a is controlled by accurately calibrated capillary tube.
- Temperature Control: Easily accessible enclosed adjustable thermostat is factory preset. Requires no adjustment other than for altitude requirements.

| Optional Accessories | | |
|------------------------|---|---|
| 51300C | Elkay WaterSentry® Replacement Filter (Bottle Fillers & ezH2O Liv® Pro) Spec Sheet (PDF) |  |

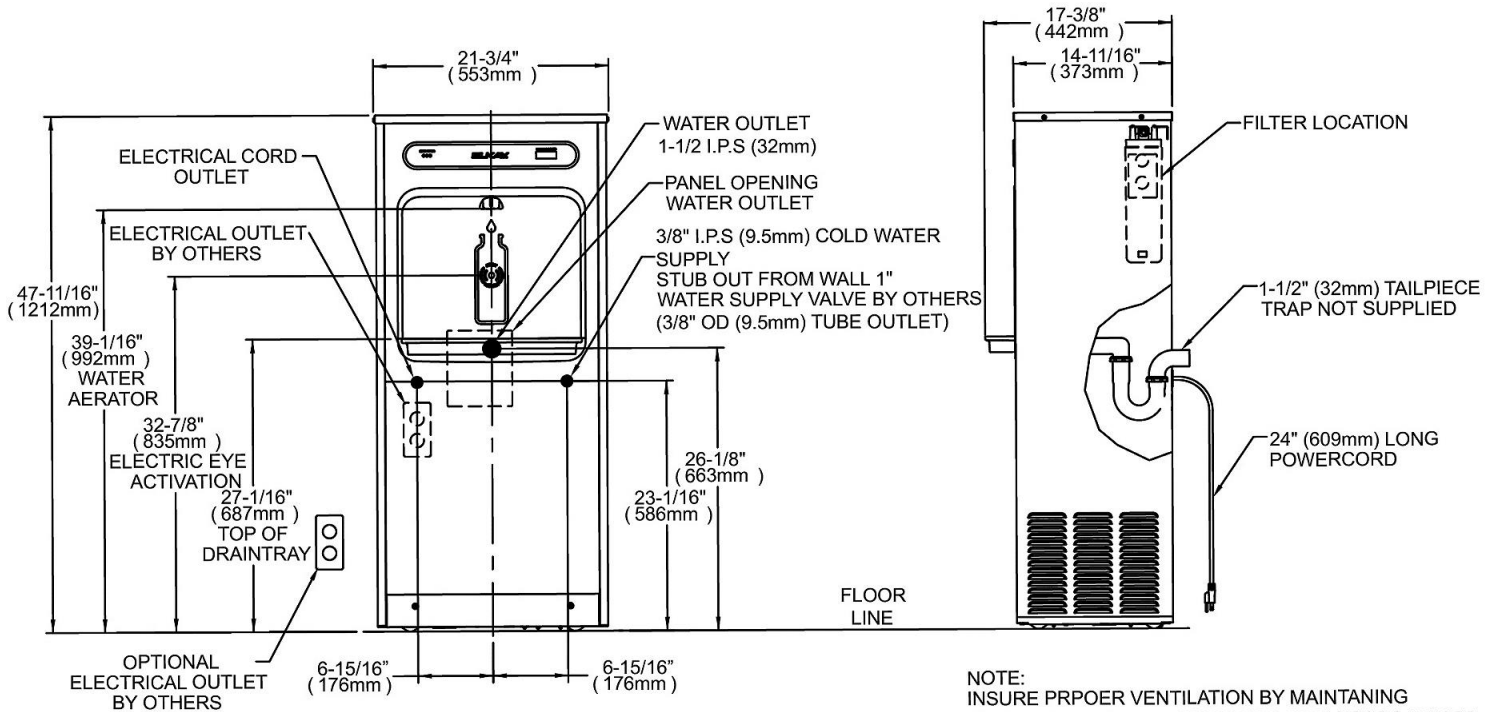

NOTE:
INSURE PROPER VENTILATION BY MAINTAINING 4" (102MM) MINIMUM CLEARANCE FROM THE CABINET LOUVERS TO THE WALL ON EACH SIDE OF THE COOLER

NOTE:
NEW INSTALLATIONS MUST USE GROUND FAULT CIRCUIT INTERRUPTER (GFCI)
IT IS HIGHLY RECOMMENDED THAT THE CIRCUIT BE DEDICATED AND THE LOAD PROTECTION BE SIZED FOR 20 AMPS

In keeping with our policy of continuing product improvement, Elkay reserves the right to change product specifications without notice. Please visit elkay.com for the most current version of Elkay product specification sheets. This specification describes an Elkay product with design, quality, and functional benefits to the user. When making a comparison of other producers' offerings, be certain these features are not overlooked.